

THE CORPORATION OF THE DISTRICT OF OAK BAY

BYLAW NO. 3550

(**amended by Bylaws No. 3648, 3823, 3916, 4087, 4113, 4126, 4163, 4280 and 4415)

A Bylaw to regulate the means of vehicular access to and from a highway

The Municipal Council of The Corporation of the District of Oak Bay, in open meeting assembled, enacts as follows:

1 In this Bylaw

"BOULEVARD FRONTAGE" means that portion of a highway lying between the roadway and the adjacent property line;

"CONCRETE DRIVEWAY" includes, in addition to a driveway access surfaced with poured concrete, but only for portions of the driveway access other than the public sidewalk, a driveway access surfaced with a top course consisting of either interlocking concrete paving bricks or an interlocking grid product of concrete or other load-bearing composition with openings designed to be filled with turf, placed in each case over the required base course and sub-base course;

*(**Bylaw No. 4415, adopted June 9, 2008)*

"CONSTRUCT" includes repair, rebuild, widen or otherwise work on;

"CRUSHED ROCK SCREENINGS" means fine aggregate resulting from the rock crushing process, with each particle having two or more fresh mechanically fractured facets;

*(**Bylaw No. 4415, adopted June 9, 2008)*

"DIRECTOR OF ENGINEERING SERVICES" means the Director of Engineering Services for The Corporation of the District of Oak Bay, or any person authorized by him to act on his behalf;

"DRIVEWAY ACCESS" means that portion of the boulevard frontage which is improved to allow vehicular access to an adjacent parcel of land;

"DRIVEWAY ACCESS PERMIT" means a driveway access permit issued pursuant to this Bylaw;

"HIGHWAY" means a street, road, lane, bridge, viaduct and any other way open to public use, but does not include a private right of way or easement over private property;

"LANE" means a highway developed for vehicular passage but not exceeding 6.1 metres in dedicated width, abutting a lot line of a parcel which is not designated as either a front lot line or an exterior side lot line pursuant to the *Zoning Bylaw, 1986*, of The Corporation of the District of Oak Bay;

*(**Bylaw 4280, adopted June 27, 2005)*

"MUNICIPAL TREASURER" means the Municipal Treasurer-Collector for The Corporation of the District of Oak Bay, or any person authorized by him to act on his behalf;

"MUNICIPALITY" means The Corporation of the District of Oak Bay;

"PRINCIPAL BUILDING" means the building used for the permitted principal use on a parcel of land;

"ROADWAY" means the portion of a highway that is designed and improved for vehicular traffic.

"PARCEL FRONTAGE" shall have the meaning assigned to the term "frontage" by the "Zoning Bylaw, 1986" of The Corporation of the District of Oak Bay.

(**Bylaw #3648, adopted May 28, 1990)

"STREET TOWNHOUSE DWELLING" means, in a townhouse development, a dwelling unit with its main entrance fronting directly onto a public highway.

(**Bylaw #4163, adopted Aug. 19, 2002)

"TOWNHOUSE DEVELOPMENT" means a parcel of land on which is constructed a residential building or buildings, each containing two or more dwelling units divided vertically by party walls, with each unit having its own outside entrance accessible from grade.

(**Bylaw #4163, adopted Aug. 19, 2002)

2 No person shall use the boulevard frontage for vehicular access between a roadway and a parcel of land except over a portion thereof constructed as a driveway access in accordance with this Bylaw.

3 No person shall construct, reconstruct, repair or replace, or cause to be constructed, reconstructed, repaired or replaced, a driveway access or any portion thereof unless he is the holder of a valid and subsisting driveway access permit issued by the Director of Engineering Services, who may refuse to issue a permit where the proposed driveway access would not comply with this Bylaw, or where the proposed location of the driveway access would, in his assessment, cause undue disturbance to any tree, shrubbery, ground cover, pole, lamp standard, electrical box or other public work or installation located on, over or under the boulevard frontage.

(**Bylaw 4280, adopted June 27, 2005)

4 A driveway access permit shall be in such form as the Director of Engineering Services may prescribe.

5 The owner of a parcel of land, or his duly authorized agent, who proposes to construct on such parcel a principal building or a garage shall, subject to Section 11, obtain a driveway access permit as a prerequisite to the issuance of a building permit unless the parcel is already served by an appropriately sited driveway access conforming to this Bylaw.

6 An application for a driveway access permit shall be made to the Director of Engineering Services and shall be accompanied by a suitably scaled drawing showing the location, dimensions and construction details of the proposed driveway access along with any physical features which may affect construction.

7 (1) No person being the holder of a valid and subsisting driveway access permit shall construct, reconstruct, repair or replace, or cause to be constructed, reconstructed, repaired or replaced a driveway access except in accordance with the approved application and the specifications and dimensions (hereinafter called the driveway access standards") set out in Schedules "B", "C", "D" and "E" attached to this Bylaw.

(**Bylaw 4280, adopted June 27, 2005)

(2) Notwithstanding Subsection (1),

(a) the repair or reconstruction of a driveway access lawfully constructed prior to February 23, 1987, whose width does not meet the driveway access standards, or which does not comply with Section 12(1), may be undertaken at the pre-existing location and width provided that:

(i) the repair or reconstruction would, when completed, create no further contravention of the driveway width portions of the driveway access

standards, or the matters regulated by Section 12(1), than that existing at the time the repair or reconstruction was started; and

- (ii) the repaired or reconstructed driveway access complies with all driveway access standards other than those governing driveway width or the matters regulated by Section 12(1), as the case may be;
*(**Bylaw 4280, adopted June 27, 2005)*

(b) where in the assessment of the Municipal Council:

- (i) the effect of the application of the driveway access standards in a specific situation would be to limit the allowable driveway access width to a dimension that does not permit reasonable access to and from a motor vehicle for a person living on the parcel served by the driveway access who because of a disability is confined to a wheelchair; and
- (ii) the development of the parcel is such that the required manoeuvring space cannot reasonably be created on private property,

then the Municipal Council may, by resolution, direct the Director of Engineering Services to issue a permit for a driveway access of specified width greater than the maximum permitted by the driveway access standards. In addition to specifying the revised maximum allowable width, such a resolution may impose conditions with respect to materials, finish and configuration, with which the owner of the property served by the driveway access shall comply

*(**Bylaw 4280, adopted June 27, 2005)*

(c) where a proposed driveway access would provide access to a parcel of land from a lane, the boulevard crossing may be developed to a width greater than the maximum calculated in accordance with the driveway access standards, but not exceeding a width which, in the assessment of the Director of Engineering Services, is required to provide safe and convenient access to a parking area lawfully developed on the parcel; and

*(**Bylaw 4280, adopted June 27, 2005)*

(d) where an existing driveway access includes a public sidewalk, the portion of the driveway access lying between the property line and the sidewalk may be repaired, reconstructed or replaced without requirement for replacement of the sidewalk portion provided, in the assessment of the Director of Engineering Services, that the reconstructed portion of the driveway access and the edge of the existing sidewalk can be joined without creating a hazard for users of the sidewalk or any other portion of the driveway access, or in the alternative, that the applicant or permit-holder, as the case may be, has paid to the Municipal Treasurer in advance an amount equal to the cost of the work required for the Municipality to create a safe transition as estimated by the Director of Engineering Services.

*(**Bylaw 4280, adopted June 27, 2005)*

(3) A footpath providing pedestrian access over a boulevard from a highway to a parcel of land shall not exceed a width of 1.1 metres, and shall be separated from a driveway access by not less than 1.5 metres at all points, with the area of separation not to be hard-surfaced or graveled.

*(**Bylaw 4280, adopted June 27, 2005)*

8 No person shall obtain a driveway access permit until he has deposited with the Municipal Treasurer

monies equal to the estimate of the cost of constructing, reconstructing, repairing or replacing the driveway access prepared by the Director of Engineering Services in accordance with Schedule "A".
(*Bylaw 4280, adopted June 27, 2005)

9 A person constructing, reconstructing, repairing or replacing a driveway access pursuant to this Bylaw shall call for inspection by the Director of Engineering Services at such stages as may be stipulated by him in the driveway access permit.

(*Bylaw 4280, adopted June 27, 2005)

10 Monies deposited pursuant to Section 8 shall be refunded only after the applicant has completed construction, reconstruction, repair or replacement of the driveway access in accordance with the driveway access standards and within the time specified in the driveway access permit, and may otherwise be applied by the Municipality to the cost of remedial work undertaken by its crews.

(*Bylaw 4280, adopted June 27, 2005)

11 On receipt of an application for a driveway access permit, and provided that the proposed driveway access complies with the driveway access standards, the Director of Engineering Services may elect to have the driveway access constructed, reconstructed, repaired or replaced by municipal crews. If the Director of Engineering Services so elects, the applicant shall pay to the Municipal Treasurer in advance of construction and, if applicable, the issuance of a building permit, an amount equal to the estimate of the cost of constructing, reconstructing, repairing or replacing the driveway access prepared by the Director of Engineering Services in accordance with Schedule "A".

(*Bylaw 4280, adopted June 27, 2005)

12 (1) For any parcel of land designated for One Family Residential(RS) Use pursuant to the 'Zoning Bylaw, 1986' of The Corporation of the District of Oak Bay, no more than one driveway access shall be constructed except where the parcel frontage exceeds 30.5 metres, in which case a maximum of one additional driveway access may be constructed provided, notwithstanding the driveway access standards, that the width of neither driveway access shall exceed 3.0 metres, and that there shall be a distance of not less than 15.0 metres between the midpoints of each driveway access.

(*Bylaw #3648, adopted May 28, 1990)

(*Bylaw #3916, adopted Oct 15, 1996)

(2) Notwithstanding subsection (1), where the parcel frontage is less than or equal to 30.5 metres, but where in the opinion of the Municipal Council the construction of an additional driveway access would provide the only practicable means of

(a) (i) remedying a shortfall between the number of parking spaces actually provided on the parcel to be served by such additional driveway access, and the number of parking spaces required to be located on that parcel under the *Parking Facilities Bylaw*; or

(ii) allowing the safe movement of traffic on and off the parcel to be served by such additional driveway access;

and in the opinion of the Municipal Council

(b) an exemption from the requirements of subsection (1) would neither

(i) substantially affect the use and enjoyment of adjacent land;

(ii) defeat the intent of subsection (1);

(iii) result in a contravention of any other bylaw; nor

(iv) create a safety hazard,

then the Municipal Council may, by resolution, instruct the Director of Engineering Services to issue a permit for an additional driveway access, provided that the width of neither driveway access shall exceed 3.0 metres.

(**Bylaw 4113, adopted March 12, 2001)

(3) For any parcel of land other than one designated for One Family Residential (RS) Use pursuant to the *Zoning Bylaw, 1986*, of The Corporation of the District of Oak Bay, no more than one driveway access shall be constructed except:

(a) where permitted by the Director of Engineering Services in order to ensure safe and efficient movement of vehicular traffic on and off the parcel; or

(b) in the case of a townhouse development containing street townhouse dwellings, where required to provide direct access from a public highway to any covered parking area attached to and forming part of an individual street townhouse dwelling, provided that the Director of Engineering Services has determined that the location of each such access would not compromise safety either for passing traffic or for vehicles using the access, and provided that for each parcel boundary abutting a highway, the cumulative width of all driveway crossings serving the parcel over that boundary does not exceed 40% of the length of the portion of the boundary common to the parcel and the highway.

(**Bylaw 4163, adopted Aug. 19, 2002)

(4) A driveway access providing access to a parcel from a lane shall not be counted for the purpose of applying subsection (1).

(**Bylaw 4280, adopted June 27, 2005)

13 A driveway access must be extended onto the parcel of land served by it in order to provide for off-street parking.

14 Where a parcel of land is proposed to be served by a driveway constructed through another parcel of land, no driveway access permit shall be issued until an easement granting the dominant tenement a right of passage is registered in the Victoria Land Title Office.

15 A driveway access permit will not be issued to provide access to a highway upon which no roadway has been constructed.

16 No driveway access shall block or hinder the flow of roadside drainage.

17 The grade of a driveway access shall not exceed 15 percent.

(**Bylaw #3648, adopted May 28, 1990)

18 Every person who offends against any of the provisions of this bylaw, or who suffers or permits any act or thing to be done in contravention or violation of any of the provisions of this Bylaw, or neglects or refrains from doing anything required to be done under this Bylaw, or who does any act or thing which violates any of the provisions of this Bylaw shall be deemed to have committed an offence under this Bylaw and shall be liable, on conviction, to a fine and penalty of not less than One Hundred Dollars (\$100.00) nor more than Two Thousand Dollars (\$2,000.00).

(**Bylaw #3648, adopted May 28, 1990)

(**Bylaw #3916, adopted Oct 15, 1996)

19 Except insofar as they repeal any other bylaw, the following bylaws are hereby repealed:

(1) Bylaw No. 3134, "*Boulevard Crossing Bylaw, 1976*";

- (2) Bylaw No. 3180, "*Boulevard Crossing Bylaw Amendment Bylaw, 1976*";
- (3) Bylaw No. 3213, "*Boulevard Crossing Bylaw Amendment Bylaw, 1977*";
- (4) Bylaw No. 3367, "*Boulevard Crossing Bylaw Amendment Bylaw, 1981*"; and
- (5) Bylaw No. 3534, "*Boulevard Crossing Bylaw Amendment Bylaw, 1986*".

PROVIDED that such repeal shall not effect any offence committed, or penalty or punishment incurred, under such repealed bylaw, and any such penalty or punishment may be imposed as if this Bylaw had not been passed.

(**Bylaw #3648, adopted May 28, 1990)

20 This Bylaw may be cited as the "**DRIVEWAY ACCESS BYLAW, 1987**".

READ a first, second and third time by the Municipal Council on February 9, 1987

RECONSIDERED, ADOPTED and FINALLY PASSED by the Municipal Council on February 23, 1987

Mayor

Municipal Clerk

Sealed with the Seal of The Corporation of the
District of Oak Bay.

Driveway Access Bylaw Schedule "A"	
Fees for the construction, reconstruction or replacement of standard** (**See Note 1) driveway accesses shall be calculated on the following unit rates: (**Bylaw 4280, adopted June 27, 2005)	
Description	Unit Rate
New or replacement driveway access, exclusive of curb and gutter	One Hundred Dollars (\$100) per square metre
Curb and Gutter -New or Replacement	Sixty Four Dollars (\$64) per lineal metre
Removal and disposal of existing driveway access	Twenty Dollars (\$20) per square metre
Curb and gutter reinstatement where an existing driveway access has been removed and/or relocated	Sixty Four Dollars (\$64) per lineal metre
Sidewalk reinstatement where an existing driveway access has been removed and /or relocated	One Hundred Dollars (\$100) per square metre
Boulevard reinstatement	Twenty Dollars (\$20) per square metre
Note 1: Fees for driveway accesses which require the installation of a culvert, other special drainage provisions, retaining walls, or blasting, or for spot repairs short of reconstruction or replacement, shall be calculated by the Director of Engineering on an actual cost basis.	

(**Bylaw 4126, adopted May 28, 2001)

(**Bylaw 4280, adopted June 27, 2005)

SCHEDULE "F"

Notwithstanding the limits on surface treatment alternatives prescribed by Schedule 'E', a driveway access may be surfaced with crushed rock screenings provided all of the following conditions and specifications are satisfied:

1. No asphalt or concrete water control or curb defines the edge of the roadway adjacent to the boundary of the parcel served by the driveway access;
2. No public sidewalk surfaced with concrete, asphalt, paving bricks or similar hard material is intersected or abutted by the driveway access; and
3. Surface crushed rock screenings are to be 9.5 mm minus in a top course of thickness not less than 75 mm, placed on a base course and sub-base course meeting the specifications set out in Schedule 'E'.
*(**Bylaw No. 4415, adopted June 9, 2008)*

SCHEDULE "B"

*SCHEDULE 'B'

MONOLITHIC SIDEWALK CROSSINGS

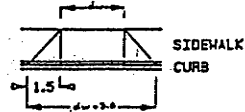

dv = driveway access width

Driveway Access Width, as a Function of Parcel Frontage

<u>Parcel Frontage</u>	<u>Required Driveway Access Width</u>
Less than or equal to 15 metres	Minimum: 3.0 metres Maximum: 3.5 metres
Greater than 15 metres, less than 26 metres	Minimum: 3.0 metres Maximum: 0.23 x (parcel frontage*)
Greater than or equal to 26 metres	Minimum: 3.0 metres Maximum: 6.0 metres

SEPARATE SIDEWALK CROSSINGS

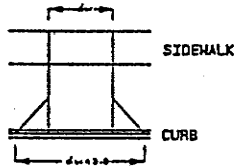

dv = driveway access width

Driveway Access Width, as a Function of Parcel Frontage

<u>Parcel Frontage</u>	<u>Required Driveway Access Width</u>
Less than or equal to 15 metres	Minimum: 3.0 metres Maximum: 3.5 metres
Greater than 15 metres, less than 26 metres	Minimum: 3.0 metres Maximum: 0.23 x (parcel frontage*)
Greater than or equal to 26 metres	Minimum: 3.0 metres Maximum: 6.0 metres

GENERAL

The width requirements set out in this Schedule shall apply to all driveway accesses constructed in One Family Residential (RS) Zones whether or not a curb or sidewalk crossing is involved.

* In metres; product to be rounded to nearest 0.1 metre

**RESIDENTIAL
S/W + BOULEVARD CROSSINGS
RS ZONES "**

MONOLITHIC SIDEWALK CROSSINGS

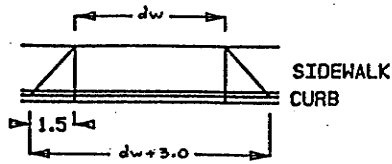

dw = driveway access width

Driveway Access Width Requirements

Minimum Width : 3.0 metres

Maximum Width : 6.0 metres

SEPARATE SIDEWALK CROSSINGS

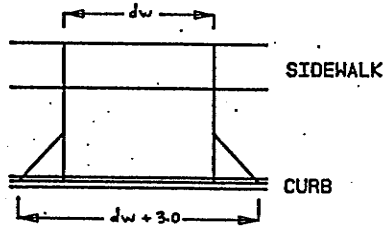

dw = driveway access width

Driveway Access Width Requirements

Minimum Width : 3.0 metres

Maximum Width : 6.0 metres

NON-RESIDENTIAL & APARTMENT
S/W & BOULEVARD CROSSINGS

DATE	REVISIONS	APPROVED
THE CORPORATION OF THE DISTRICT OF OAK BAY ENGINEERING DEPARTMENT		
APPROVED BY: <i>C. F. O'Horman</i>		STD. DWG. NO.
DATE:	1986: 12: 15	R 3
SCALE:	1 : 200	

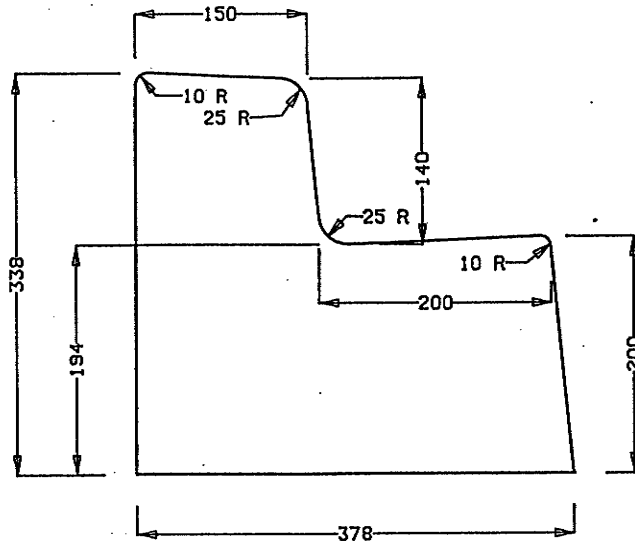

NON-MOUNTABLE CURB

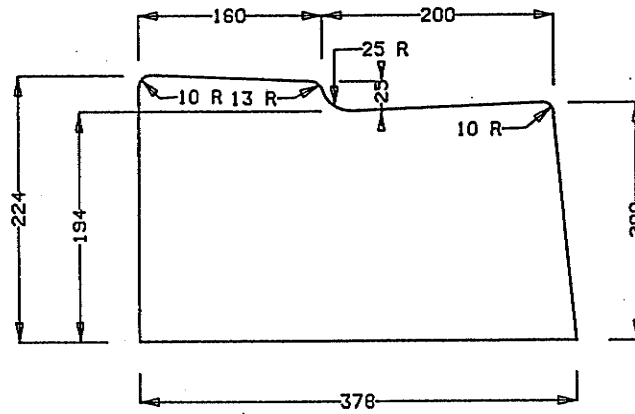

CURB AT DRIVEWAY CROSSING

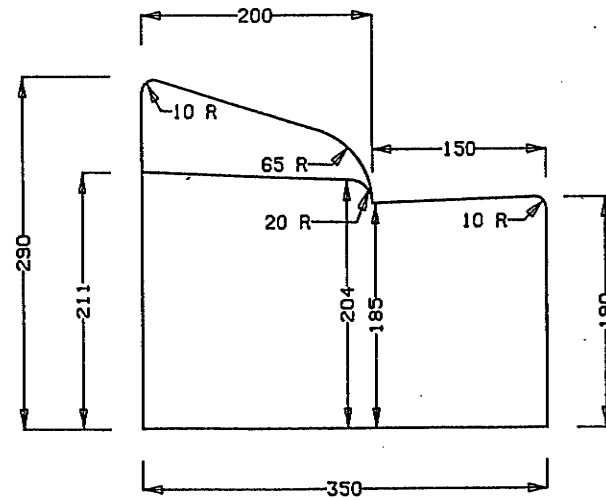

ROLL CURB

CURB AND GUTTER

DATE	REVISIONS	APPROVED
THE CORPORATION OF THE DISTRICT OF OAK BAY ENGINEERING DEPARTMENT		
APPROVED BY:	<i>C. F. O'Hanrahan</i>	STD. DWG. NO.
DATE:	1986: 12: 15	R 1
SCALE:	1 : 5	

SCHEDULE "E"

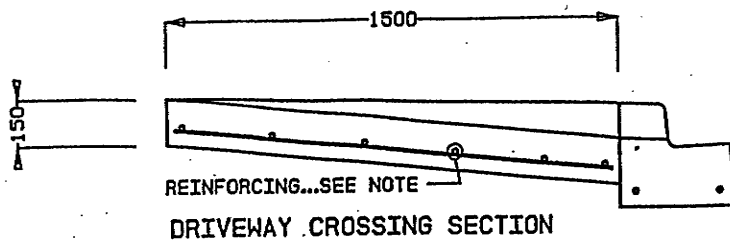

DRIVEWAY CROSSING SECTION

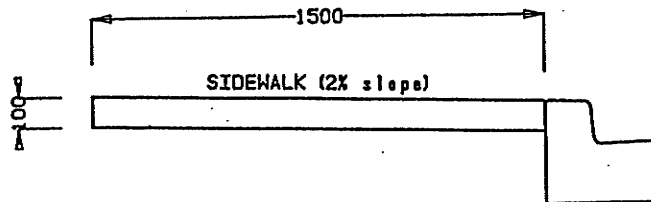

SIDEWALK SECTION

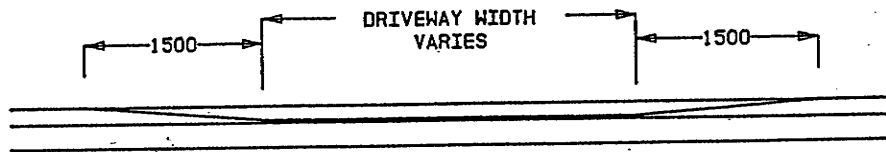

DRIVEWAY CROSSING - FRONT ELEVATION

DRIVEWAY ACCESS FINISH COAT THICKNESSES FOR PERMITTED SURFACES

Concrete Driveway	150 mm
Concrete Sidewalk	100 mm
Asphalt Driveway *	80 mm

*permitted only where the edges of the roadway are not defined by a concrete sidewalk, concrete curb, or both [Bylaw 3648 - May 28, 1990]

NOTES

For Curb and Gutter Details - see Standard Drawing No. R 1

Reinforcing to be 4 m - 300 mm E/W required for commercial driveways

Final Base Material to be: 100 mm of 20 mm minus crushed gravel placed on a compacted sub-base course of pit-run gravel or equivalent, not less than 100 mm thick, providing a stable structural support for the base course and wearing surface.

Curb and Gutter to be steel trowel finish

Sidewalk to have a brush finish

Driveway Construction Joints: 3 m x 3 m panels

CONCRETE MIX SPECIFICATIONS

Cement Type	10
Compressive Strength @ 28 days	30 MPa
Maximum Size Aggregate	20 mm
Class of Exposure	Class A
Slump	80 ± 1 mm
Air Content	6 ± 1%

CURB, GUTTER & SIDEWALK

DATE	REVISIONS	APPROVED
THE CORPORATION OF THE DISTRICT OF OAK BAY ENGINEERING DEPARTMENT		
APPROVED BY:	<i>C. F. O'Horman</i>	STD. DWG. NO.
DATE:	1986: 12: 15	R 4
SCALE:	1 : 20	